

Technical Information

No. FO 4913

Edition: 04/2003 - subject to change

Supersedes: edition 03/99

Status: valid

Guidelines for Mounting and Centring of Reflector Discharge Lamps (1)

■ Scope

These guidelines pertain to the following lamp types:

- HBO® R 103 W/45
- XBO® R 100 W/45 (C) OFR
- XBO® R 101 W/45C OFR
- XBO® R 180 W/45 (C) OFR
- XBO® R 181 W/45C OFR
- HTI® 250 W/22 (C)
- HTI® 250 W/32 (C)
- HXP™ R 120W/45C UV
- HXP™ R 120W/45C VIS

■ General characteristics

- Mounting ring made of ceramics
- Positioning notch
- Suitable for three-point-support
- Polished surfaces for exact centring

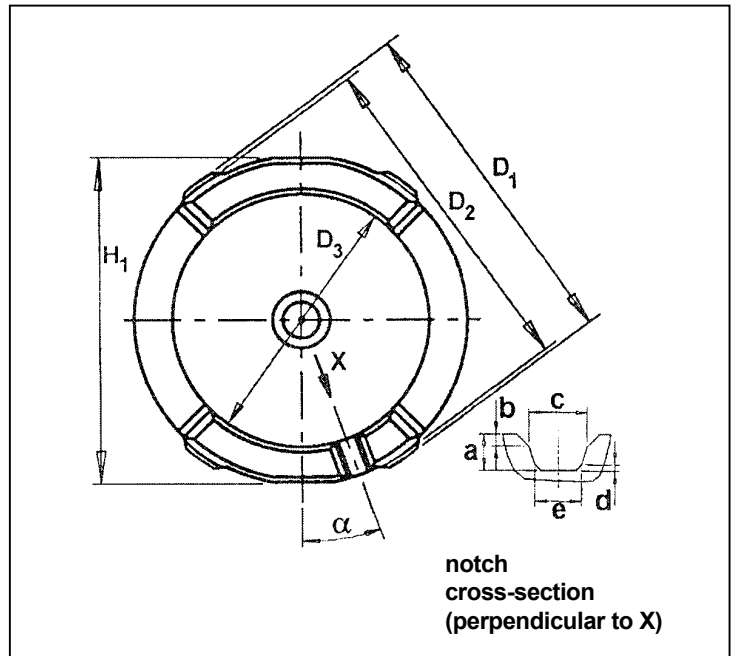

Fig. 1: Ring geometry

■ Ring geometry and positioning notch

Listed items shown in Figure 1

Position of notch	α	deg	20
Notch geometry	a	mm	3.0 ± 0.15
	b	mm	$1.0 \pm 0.15 \times 45^\circ$
	c	mm	5.0 ± 0.2
	d	mm	$0.5 \pm 0.15 \times 45^\circ$
	e	mm	4.0 ± 0.15
Diameter	D_1	mm	max. $\varnothing 67.0$
	D_2	mm	$\varnothing 64.0_{-0.3}$
	D_3	mm	min. $\varnothing 47.5$
Height (overall)	H_1	mm	max. 62.0

Comments:

It is recommended to use the notch to achieve reproducible lamp-to-lamp positioning.

Technical Information

No. FO 4913

Edition: 04/2003 - subject to change

Supersedes: edition 03/99

Status: valid

Guidelines for Mounting and Centring of Reflector Discharge Lamps (1)

■ Three-point-support

Position of areas that can be used for support:

S_1	mm	min. \varnothing 62.0
S_2	mm	max. \varnothing 51.5
H_2	mm	min. 60.0
β_1	deg	82
β_2	deg	54
β_3	deg	20

Comments:

It is recommended to provide a three-point-support at the hatch-marked areas shown in Figure 2. They define the reference plane of the lamp. The lamp should be pressed against the support.

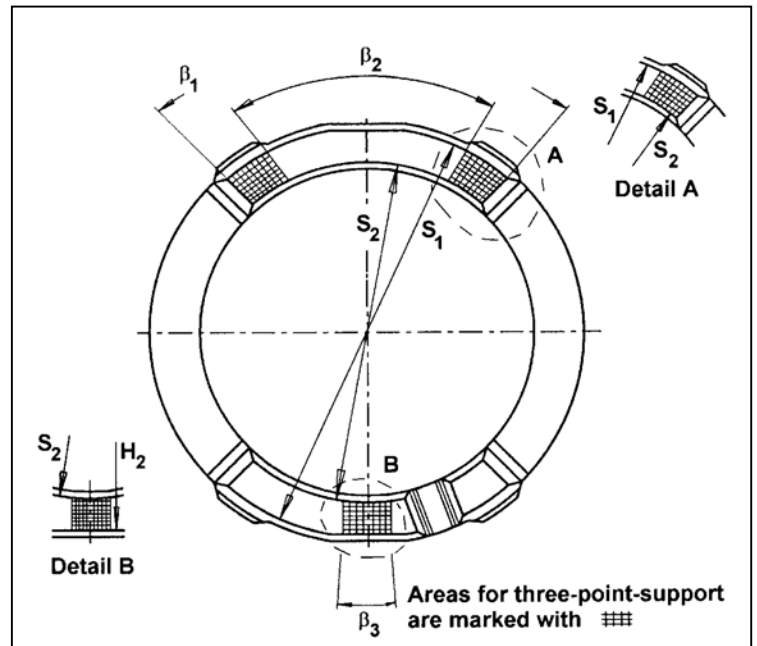

Fig. 2: Three-point-support. Areas to be used for three-point-support are symmetrical referring to vertical axis.

■ Possibility of exact centring

Position of centring surfaces:

D_1	mm	max. \varnothing 67.0
D_2	mm	\varnothing 64.0 $_{-0.3}$
f ¹⁾	mm	min. 3.0
χ_1	deg	42
χ_2	deg	30
χ_3	deg	72

Comments:

It is recommended to centre the lamp by gripping the centring surfaces shown in Figure 3.

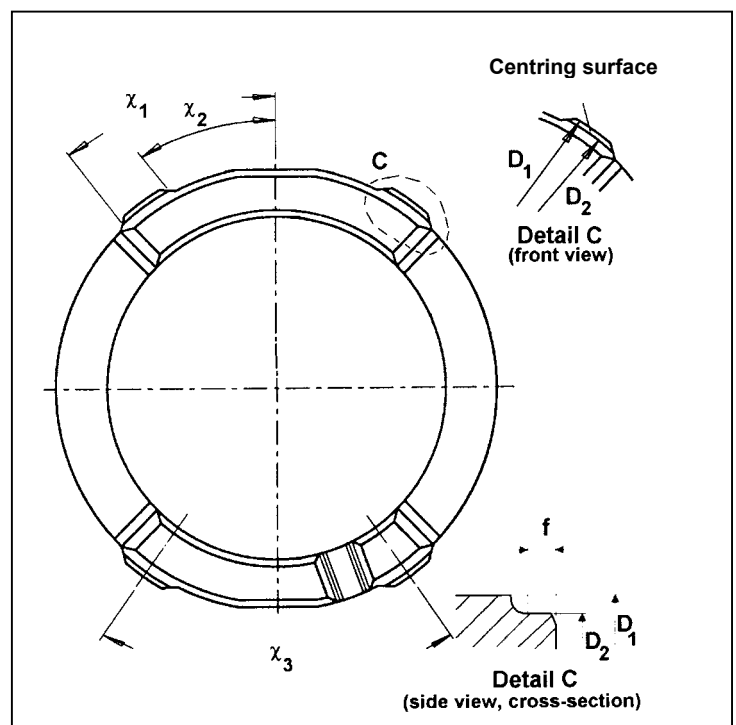

Fig. 3: Centring surfaces

1) Dimension „f“ denominates the depth of centring surfaces in the direction perpendicular to the reference plane defined by three-point-support. Dimension “f” is not specified in terms of maximum depth.